

HARDMATIC HH-300

Durometers for Rubber and Plastics Hardness Testing

CATALOG No. E4137-811



Hardness testing instruments for rubber and plastics

Mitutoyo

DIGITAL/ANALOG DUROMETERS series 811

Hardness testing instruments for rubber and plastics

Easy-to-use hardness testing instruments. All you have to do is just hold the Durometer by hand, push it onto a sample, and read the displayed value. Samples of varying hardness, ranging from soft rubber to hard plastic, can be tested. Mitutoyo's Durometers conform to global industrial standards, and are ideal quality control tools for ISO9000 registration.



Compact Type

- The Durometer fits naturally into your palm during measurement and, off course, is portable.



Long-leg Type

- This type of Durometer is capable of measuring the hardness of the bottom of grooves and holes in addition to flat surfaces. The Durometer lets you keep your hands and face a comfortable distance away from high-temperature samples that may have just been molded.



Mitutoyo

FEATURES

- Durometers are suitable for testing natural rubber, neoprene, polyesters, P.V.C., leather, thiokol, nitril rubber, wax, vinyl, cellulose acetates, glass polystyrol, and other materials.
- Mitutoyo's Durometers are manufactured in accordance with ASTM D 2240, ISO 868, ISO 7619, DIN 53 505, JIS K 6253, and JIS K 7215 specifications.
- Units are available in both Shore A and Shore D scales, and will test a wide variety of applications.
- The analog durometer is provided with a peak retaining hand for error-free reading.
- The digital durometer is provided with data freezing function, and permits the operator to make an error-free reading on the clear LCD screen.
- Data output function.



FUNCTIONS

DATA HOLD:

The displayed value on Digital Durometers can be held at any time during measurement. This is a very helpful feature for correctly reading measurement values.

PEAK RETAINING HAND:

The Analog Durometers have a maximum value retaining hand that allows the operator to make error-free readings of measurement values.



During measurement



Result

Standard Accessories

Order No.

938882 SR44 Battery (Only digital)

HOLDING BAR

The holding bar is used to mount the Compact Type Durometer on a general drilling machine. This permits the operator to perform hardness measurement in a comfortable position.

Optional Accessories

Order No.

19BAA180 Holding bar

811-013 Testing stand CTS-103 (Shore A)*

811-014 Testing stand CTS-104 (Shore D)*

811-019 Testing stand CTS-101 (Shore A)**

811-012 Testing stand CTS-102 (Shore D)**

811-017 Auxiliary weights CA (Shore A)

811-018 Auxiliary weights CD (Shore D)

*Only available on Compact Type Durometer

**Long-leg Type Durometer attachment is included.

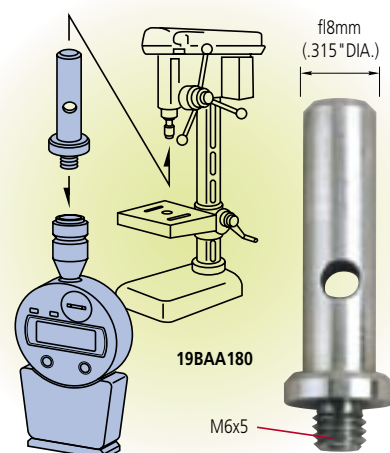



TESTING STAND APPLICATIONS

These stands are used to mount Durometers. They allow constant-pressure hardness measurement by pressing the Durometer vertically on a workpiece.

- (1) Anyone can perform repeatable hardness measurement due to fewer possibilities of human error and measurement variations.
 - (2) The supplied weights can be attached directly to a Durometer and allow constant-pressure hardness measurement of large samples for which a stand cannot be used.
 - (3) The supplied weights are used for calibrating the spring tension of Durometers.
- Workstage dimension: $\varnothing 90\text{mm}$
 - Maximum sample height: 90mm

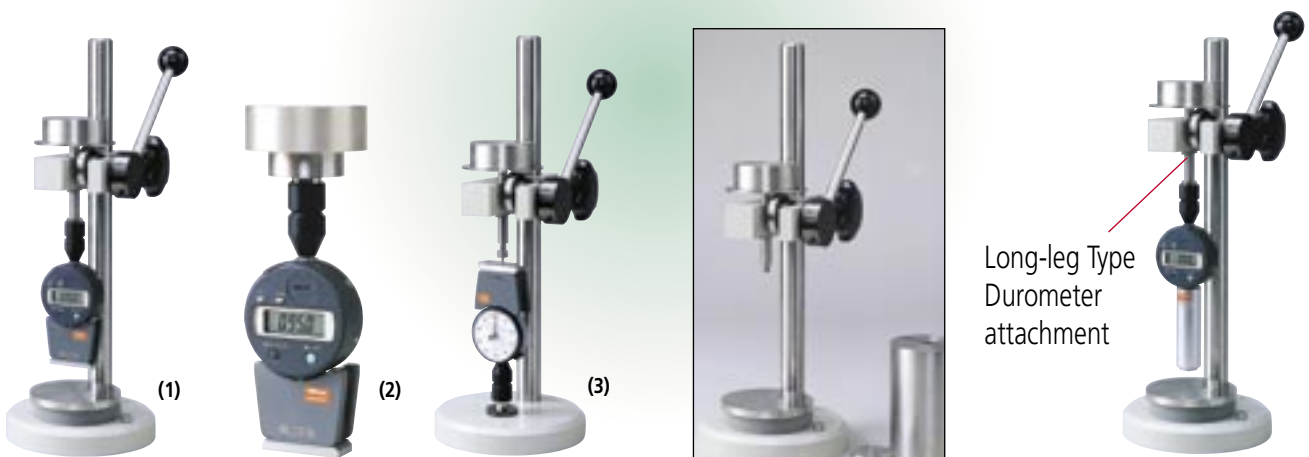

REFERENCE STANDARDS

ASTM D 2240:	"Standard Test Method for Rubber Property — Durometer Hardness"
ISO 7619:	"Rubber — Determination of Indentation Hardness by means of Pocket Hardness Meters"
ISO 868:	"Plastics and Ebonite — Determination of Indentation Hardness by means of a Durometer (Shore Hardness)"
DIN 53 505:	"Testing of Rubber and Plastics; Shore A and Shore D Hardness Test"
JIS K 6253:	Hardness Testing Methods for Rubber, Vulcanized or Thermoplastic
JIS K 7215:	Testing Method for Durometer of plastics

Dimensions

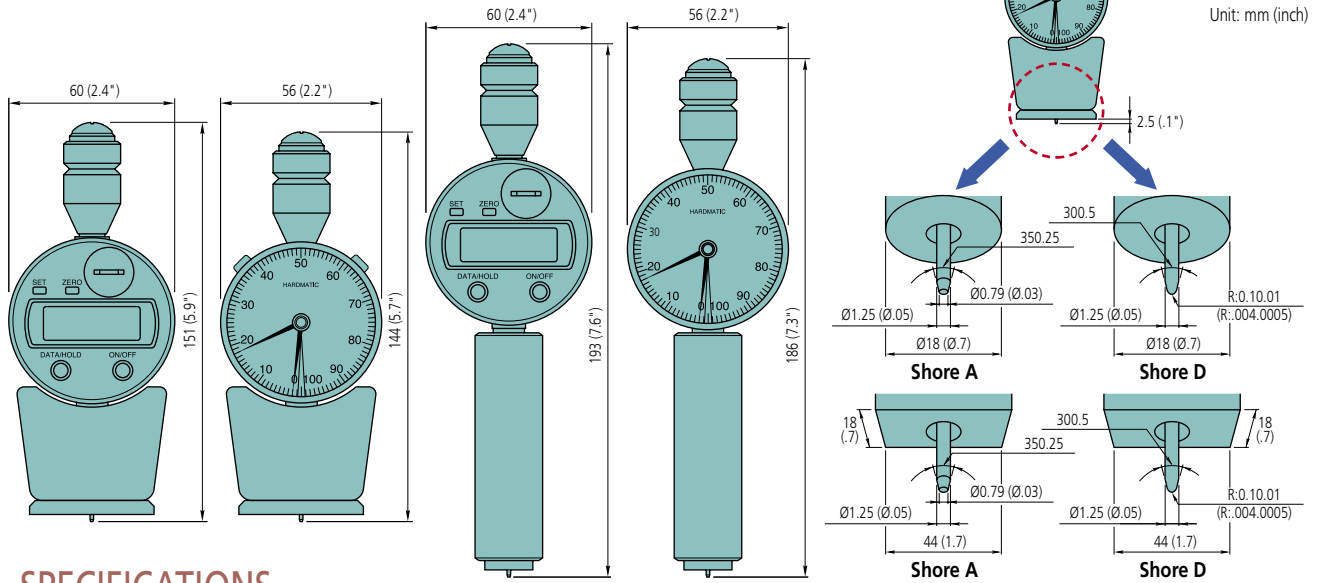

SPECIFICATIONS

Order No.	Digital	811-336	811-336-01	811-332	881-338	811-338-01	811-334
	Analog	811-335	811-335-01	811-331	881-337	811-337-01	811-333
Model No.	Digital	HH-336	HH-336-01	HH-332	HH-338	HH-338-01	HH-334
	Analog	HH-335	HH-335-01	HH-331	HH-337	HH-337-01	HH-333
Scale	Shore A			Shore D			
Applications	Natural rubber, soft elastomers, etc.			Hard elastomers, plastics, hard rubber, ebonite, etc.			
Resolution	0.5 (Digital Durometer) or 1 (Analog Durometer)			0.5 (Digital Durometer) or 1 (Analog Durometer)			
Range	10 - 90			20 - 90			
Standards	ASTM D 2240	✓	✓	✓	✓	✓	✓
	ISO 868	✓	✓	✓	✓	✓	✓
	ISO 7619	✓	✓	✓	✓	✓	✓
	DIN 53 505	—	✓	✓	—	✓	✓
	JIS K 6253	✓	✓	✓	✓	✓	✓
	JIS K 7215	✓	✓	✓	✓	✓	✓
Pressure foot	44x18mm (1.73"x.71")	ø18mm (.71" DIA.)		44x18mm (1.73"x.71")	ø18mm (.71" DIA.)		
Spring force (mN)	550+75H (H:Reading 10-90)			444.5H (H:Reading 20-90)			
Indenter	Blunt taper (Tip diameter: 0.79mm)			Sharp point (Tip curvature: 0.1±0.01mm)			
Tip angle	35°±0.25°			30°±0.5°			
Indenter diameter	1.25mm (.05")						
Indenter protrusion	2.5mm (.1")						
Functions	Digital Durometer: Data hold, zero -setting, SPC output, power ON/OFF (Power supply: SR44 battery x 1pc.) Analog Durometer: Peak retaining hand						
Type	Compact		Long-leg		Compact		Long-leg
Dimensions (WxDxH)	Digital	60x28.5x151mm (2.36"x1.12"x5.94")	60x29.5x193mm (3.36"x1.16"x7.60")	Digital	60x28.5x151mm (2.36"x1.12"x5.94")	60x29.5x193mm (3.36"x1.16"x7.60")	
	Analog	56x33x144mm (2.20"x1.32"x5.67")	56x34.5x186mm (2.20"x1.36"x7.32")	Analog	56x33.5x144mm (2.20"x1.36"x5.67")	56x34.5x186mm (2.20"x1.36"x7.32")	
Mass	Digital	290g	310g	Digital	290g	310g	
	Analog	300g	320g	Analog	300g	320g	

Notes 1: The allowable values of spring force and needle protrusion of the digital type defined in DIN 53 505 are in compliance with JIS, ISO, and ASTM.

2: For products in compliance with the following standards, please contact Mitutoyo. •ASTM D 2240 Type B, Type C, Type DO, Type O, Type OO

*In the JIS standards, JIS K 6301 "Physical testing methods for rubber, vulcanized or thermoplastic" is now obsolete. (For details, refer to the official gazette dated July 21 1998.)



Coordinate Measuring Machines	11
Vision Measuring Systems	12
Form Measurement	13
Optical Measuring	14
Sensor Systems	15
Test Equipment and Seismometer	16
Digital Scale and DRO Systems	17
Small Tool Instruments and Data Management	18

Note: All our product details, in particular the illustrations, drawings, dimensional and performance details and other technical specifications contained in this publication are to be considered to be approximate average values. To this extent, we reserve the right to make changes in design, technical data, dimensions and weight. Our specified standards, similar technical rules and technical specifications, descriptions and illustrations of the products are correct at the time of printing. The current version of our general terms and conditions also apply. Only offers which we have submitted can be considered to be definitive.

Mitutoyo Corporation
20-1, Sakado 1-Chome,
Takatsu-ku, Kawasaki-shi,
Kanagawa 213-8533, Japan
T +81 (0) 44 813-8230
F +81 (0) 44 813-8231
<http://www.mitutoyo.co.jp>

Mitutoyo